

# Crush Pad Solutions

## Your label deserves a flawless grape

Wine Business Monthly calls the sorting table “the last line of defense between the vineyard and the winery.” For that reason, Key has designed the **Grape Receiving and Inspection Platform (GRIP)** and other modular equipment to help small to medium-sized wineries achieve the highest quality product in a highly efficient process.



## The Key GRIP system

### Receiving Hopper

- **Dump entire tote at once...** and drive away; no manual tipping or pulling product to the inspection table
- **Free forklift operators** to perform other tasks
- **Precisely meter clusters** to optimize manual inspection
- **Present grapes at adjustable vibratory speeds** to spot and remove Material Other than Grapes (MOG) without bridging or plugging

### Receiving/Inspection Platform

- **Gain mobility** - wheel out of area when not in use
- **Integrate easily** with destemmer; adjustable heights

### Cluster Sorting Table\*

- **Match sorting table speed with destemmer** to increase efficiency and prevent thrashing and stem-shredding
- **Clean and sanitize in minutes** to effortlessly changeover between varieties

*\*Also available as stand-alone unit*



*Grape Receiving and Inspection Platform (GRIP)*

**Key Technology**

150 Avery Street • Walla Walla, WA 99362 • USA

Phone: 509.529.2161 • Fax: 509.527.1331 • [product.info@key.net](mailto:product.info@key.net) • [www.key.net](http://www.key.net)



## Post-Destemmer Sorting Table

A second vibratory sort utilizes gravity and stainless steel screens to increase product quality by eliminating residual MOG before fermentation.

- **Avoid clumping** - gentle vibration immediately spreads single grapes exiting the destemmer
- **Reduce labor** - small sheared stem, jacks, raisins and insects fall through openings in screen
- **Clean and sanitize easily** - simple, all-stainless design
- **Extract efficiently** - juices may be directed to the must pump intake

## More Winemaking Solutions

**Impulse™ Electromagnetic Conveyor** - for instant start/stop and precise metering, preventing overloading the destemmer/crusher.

**Belt Conveyor** - accommodates high-capacity feeding to the Cluster Sorting Table, holding several totes of product at once.

**2X Air Cleaner** - Save costs by removing 98% of light MOG.

**Color Sorters** - for the ultimate control of MOG and grape quality.

*Also: rejected material trough, jack removal shaker, jack inspection shaker, bin dumper*

## What vintners are saying:

*“With Key’s Grape Receiving and Inspection Platform (GRIP), we save a driver and a fork lift because we can dump the entire bin at one time. But more importantly, the even flow of product helps us maximize quality. Product comes to the inspection table at a perfectly constant flow -- the equipment is awesome.”*

**JEAN-FRANÇOIS PELLET, ARTIFEX WINE COMPANY**

*“We couldn’t have asked for more. The new sorting shaker proved outstanding. It allowed us to hand-sort our crop to eliminate any foreign objects or clusters that were not of optimum quality. It truly is a work of art.”*

**NORM MCKIBBEN, PEPPER BRIDGE WINERY**

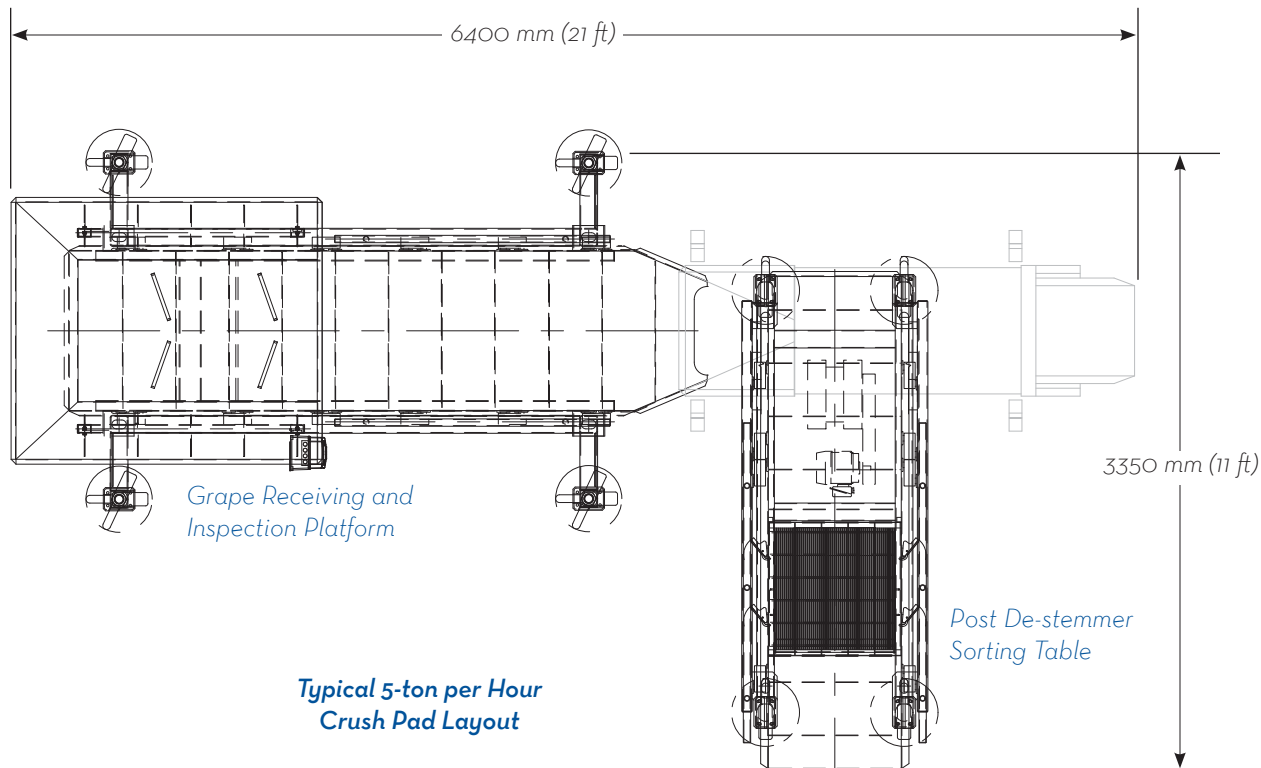

Post De-stemmer  
Sorting Table